

T50P



TRACTOR SERIES



NEW ENERGY FORKLIFT LEADER

BYD Efficient Lithium-Ion Electric Forklift

byd-forklifts.com

STANDARD FEATURES

Safety

- Slope protection
 - Programmable automatic speed limit
 - Operator presence sensing
 - Low SOC protection
 - Charging protection
 - Dual Emergency Power Off Button
 - Hill-holding function
-

Performance

- Lithium iron-phosphate battery
 - AC drive system
 - Small turning radius
 - Battery rapid charging & opportunity charging
 - Digital (LCD) multifunction display
 - Time & date
 - OPS time accumulator
 - Battery capacity indicator
 - Parking brake indicator
 - Direction indicator
 - Maintenance indicator
 - Self-diagnostics
 - Built-in analyzer
-

Operability & ergonomics

- Heavy-duty non-slip pedal
 - Electric power steering
 - Front combination lights
 - Rear combination lights
 - Back up buzzer
 - Easy connection charging port
-

Serviceability

- AC brushless drive motor
 - DC steering motor
 - Diagnostic connection at charging port
 - Maintenance-free battery pack
 - Easy-access controllers
 - Easy-lift battery hood
-

OPTIONAL EQUIPMENT

Lights & indicators

- Strobe light
-

Body

- Half-sealing cabin (with rain curtain)
 - Half-sealing cabin (no rain curtain)
 - No cabin
 - Special key
-

Wheels & tires

- Solid
- Non-marking tire
- Pneumatic

TRACTOR SPECIFICATIONS

Characteristic	Manufacturer			BYD		
	Model			T50P		
	Power Unit			Electric		
	Operation			Seat		
	Load Capacity	Q	lbs	kg	11023	5000
	Rated Tractive Force	F	lbf	N	337	1500
	Wheelbase	y	in	mm	40	1013
Weights	Service Weight		lbs	kg	2161/2315	980/1050
	Axle Load with Load, Front(130/270Ah)		lbs	kg	926/937	420/425
	Axle Load with Load, Rear(130/270Ah)		lbs	kg	1235/1378	560/625
Wheels	Tire Rubber, SE, Pneumatic, Polyurethane			Pneumatic / SE		
	Tire Size, Front			4.00-8		
	Tire Size, Rear			5.00-8		
	Wheels, Number Front/Rear (x = Driven)			2/2x		
	Track Width, Front	b10	in	mm	9	229
	Track Width, Rear	b11	in	mm	33	835
Dimensions	Height of Seat/Stand on Platform	h7	in	mm	39	980
	Towing Coupling Height	h10	in	mm	13±3	332±80
	Front/Rear Overhang	l5	in	mm	41/25	402/385
	Overall Length	l1	in	mm	71	1800
	Overall Width	b1/b2	in	mm	39	980
	Ground Clearance, Centre of Wheelbase	m2	in	mm	4	110
	Turning Radius	Wa	in	mm	62	1580
Performance	Travel Speed, with/without Load		mph	km/h	7/9	11/14
	Maximum Tractive Force		lbf	KN	1686	7.5
	Approach/Departure Angle	α	°	°	35/21	
	Climbing Ability, with/without Load		%	%	10/20	
	Service Brake				Hydraulic brake	
Drive	Drive Motor, 60 Minute Rating		HP	kw	7	5.5
	Battery Voltage/Rated Capacity		V/Ah	V/Ah	48/130(270)	
	Battery Weight (± 5%)		lbs	kg	342/562	155/225
Other	Type of Drive Control				AC	
	Noise Level at Operator's Ear		dB(A)	dB(A)	≤80	
	Towing Coupling Type				PIN	

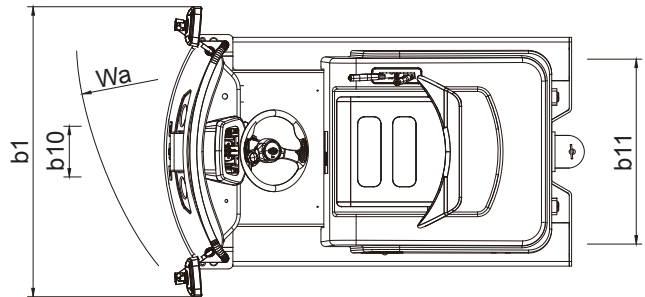
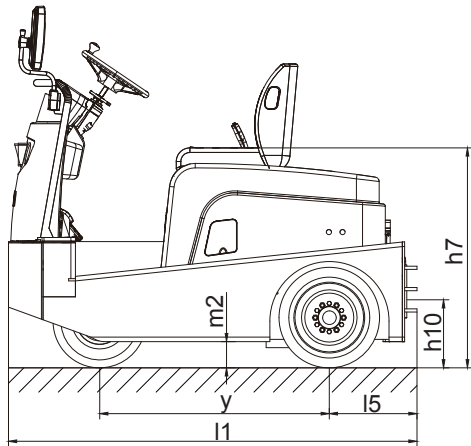

BYD Forklift production site is certified:
ISO 9001 ISO 14001 OHSAS 18001



BYD trucks conform to the
 United States Safety Requirements
 All BYD forklifts comply with ANSI B56.1



BYD Motors LLC

661-940-3255

sales@byd-forklifts.com

byd-forklifts.com