



ECB16Di ECB18Di ECB20SD

BYD COUNTERBALANCE FORKLIFT
4-WHEELER (1600kg/1800kg/2000kg)

**CHANGE YOUR MIND
NOT YOUR BATTERY**

 Lithium / **8** YRS **15,000**HRS Battery Warranty / BYD Iron-Phosphate

Core Technology

With many years of experience and innovation, BYD has the most reliable battery technology.

BYD started as a battery manufacturer, producing its first battery in 1997. Currently, BYD batteries are widely applied to passenger vehicles, cabs, buses, coaches, logistic vehicles, sanitation trucks and other commercial vehicles. In order to

accomplish that, we believe in technology innovation and rigorous production processes. BYD batteries have been road-proven in over 1.7 million new energy passenger cars and over 70,000 electric buses around the world.

We are constantly refining our manufacturing, pack design and interconnection hardware to further enhance the battery safety profile. Samples from each batch must pass rigorous impact, collision, vibration and external fire testing before being released for electric vehicle integration.



BYD Iron-Phosphate technology

BYD Iron-Phosphate electric forklift batteries are a major revolution for the industry. A solution for the present and future, synonymous with savings, sustainability, cleanliness, safety and care for the environment.



The BYD battery revolution

BYD has accumulated vast experience to predict and respond to global sustainability challenges. Currently, BYD's patented BYD Iron-Phosphate batteries have been used in over 40 vehicle models, including passenger, commercial, and off-highway vehicles.

Compared to equivalent equipment powered by traditional lead acid batteries, BYD batteries require no maintenance, have a shorter charge time, a longer working life, and use up to 40% less energy. Combined with BYD's intelligent chargers, charging from empty to full can be achieved in under an hour, providing comfortably enough charge for a full eight-hour shift. Furthermore, BYD batteries can be topped-up during short breaks in operations, thus guaranteeing maximum uptime at the lowest-possible cost.

Unlike other Lithium-ion batteries featuring on competitors' forklifts, BYD designs, develops and manufactures its own batteries and chargers, meaning the entire energy ecosystem is optimised to offer maximum performance for your investment.

BYD Iron-Phosphate Battery

Savings

No battery changes, no maintenance, no distilled water or charger room, and with an energy consumption which is well below average.

Sustainable

No pollution from heavy metals or corrosive acid, making BYD Iron-Phosphate batteries the most ecologically friendly on the market.

Safety

No risk of explosion or fire, no flammable gases emissions, nor harm to the health of your employees.

Opportunity Charging

Battery can be partially topped up frequently e.g. during lunch break with no detriment to battery life or capacity.

Long life

Unrivalled industrial leading warranty 8 year/15,000 hours thanks to BYD active battery protection system standard in 1.5 GEN models.

Fast-Charging

Charging power up to 16kW, with possibility to reduce charging time down to 1 hour, as compared to 8-12 hours charging time for lead acid batteries.



ECB16Di ECB18Di ECB20SD

Electronic Parking Brake Auto Switch-off

The electronic parking brake is incorporated into the range. It provides the advantage of automatic battery switch-off, a safety feature that prevents the battery draining if left unattended for an extended period of time.



High full load capacity

The new forklift has improved stability and load capacity, with a 4000mm lift height @ 500 LC with full load capacity.



Easy-on two steps pedal

The product provides a two-stage boarding pedal, providing a more user-friendly operation condition.



Remodeled Steering Axle

With a larger steering angle now achievable, the overall turning radius of the forklift is minimised with a reduction of 3.57% to increase manoeuvrability in tight areas such as warehouse aisles.

ECB16Di/ECB18Di/ECB20SD Counterbalance Forklifts Specifications

Identification	1.1	Manufacturer			BYD	BYD	BYD
	1.2	Model			ECB16Di	ECB18Di	ECB20SD
	1.3	Drive			Electric	Electric	Electric
	1.4	Operator type			Seat	Seat	Seat
	1.5	Rated capacity	Q	kg	1600	1800	2000
	1.6	Load center	c	mm	500	500	500
	1.8	Load distance, center of drive axle to fork	x	mm	393	393	409
	1.9	Wheelbase	y	mm	1400	1400	1450
	Weights	2.1	Service weight		kg	3130	3310
2.2		Axle load, with load, front/rear		kg	4155/575	4489/621	4943/677
2.3		Axle load, without load, front/rear		kg	1522/1608	1520/1790	1672/1948
Wheels	3.1	Tyres			SE	SE	SE
	3.2	Tyre size, front			18x7-8	200/50-10	200/50-10
	3.3	Tyre size, rear			16×6-8	16×6-8	16×6-8
	3.5	Wheels, number front rear (X=driven wheels)			2x/2	2x/2	2x/2
	3.6	Track width, front	b10	mm	890	932	932
	3.7	Track width, rear	b11	mm	855	855	855
Basic Dimensions	4.1	Tilt of mast/fork carriage forward/backward	a/b	deg	5/7	5/7	5/8
	4.2	Height, mast lowered	h1	mm	2020	2020	1990
	4.3	Free lift	h2	mm	120	120	150
	4.4	Lift height	h3	mm	3000	3000	3000
	4.5	Height, mast extended	h4	mm	3985	3985	4040
	4.7	Height of overhead guard	h6	mm	2050	2050	2050
	4.8	Seat height	h7	mm	985	985	985
	4.12	Coupling height	h10	mm	480	480	480
	4.19	Overall length	l1	mm	3195	3195	3260
	4.20	Length to face of forks	l2	mm	2125	2125	2190
	4.21	Overall width	b1	mm	1100	1130	1130
	4.22	Fork dimensions	s/e/l	mm	40/100/1070	40/100/1070	40/100/1070
	4.23	Fork carriage ISO 2328, class/type A, B			2A	2A	2A
	4.24	Fork carriage width	b3	mm	1040	1040	1040
	4.31	Ground clearance, with load, below mast	m1	mm	95	95	95
	4.32	Ground clearance, center of wheelbase	m2	mm	95	95	95
	4.34.1	Aisle width for pallets 1000x1200 crossways	Ast	mm	3404	3404	3474
4.34.2	Aisle width for pallets 800x1200 lengthways	Ast	mm	3560	3560	3634	
4.35	Turning radius	Wa	mm	1755	1755	1815	
Performance Data	5.1	Travel speed, with/without load		Km/h	16/16	16/16	16/16
	5.2	Lift speed, with/without load		mm/s	500/55	500/55	450/480
	5.3	Lowering speed, with/without load		mm/s	530/50	530/50	480/450
	5.6	Maximum tractive force, with/without load		KN	9.0/7.9	9.0/8.0	9.0/8.0
	5.8	Max. gradeability, with/without load		%	20/20	18/20	15/20
	5.10	Service brake			hydr.	hydr.	hydr.
	6.1	Drive motor rating S2 60 min.		kW	2×6.5	2×6.5	2×6.5
Motor	6.2	Lift motor rating at S3 15%		kW	16	16	16
	6.4	Battery voltage/kwh		(v/kwh)	80/21.6	80/21.6	80/21.6
	6.5	Battery weight		kg	620	620	620
	8.1	Type of drive control			AC	AC	AC
Others	10.1	Operating pressure for attachments		Mpa	16	18	≤16
	10.7	Noise level at operator's ear		(dB(A))	≤75	≤75	≤75
	10.8	Trailer			PIN	PIN	PIN

*BYD reserves the right to alter and modify the design, features and technical parameters of its products at any given time and without pre-advance, as products are subject to ongoing and continuous development.

ECB16Di/ECB18Di MAST TABLE

- h3 Lifting Height (mm)
 h2 Full Free Lift Height (mm) (Load Backrest 1000mm)
 h1 Height, Mast Fully Lowered (mm)
 h4 Height, Mast Fully Extended (mm) (Load Backrest 1000mm)
 α Tilt Forward
 β Tilt Backward

Mast spec (mm)	h3	h2 (with backrest)	h1	h4	α	β	Residual Capacity (kg)(without attachment)			
							ECB16Di @500MM/@600MM		ECB18Di @500MM/@600MM	
2-stage Standard Mast	3000	130	2020	4040	5°	7°	1600	1561	1800	1759
	3500	130	2270	4540	5°	7°	1600	1500	1800	1692
	4000	130	2570	5040	5°	7°	1600	1443	1766	1629
	4500	130	2820	5540	5°	5°	1503	1389	1698	1570
	5000	130	3120	6040	5°	5°	1354	1339	1634	1514
2-stage FFL mast	3000	1020	2020	4040	5°	7°	1600	1572	1800	1770
	3300	1170	2170	4340	5°	7°	1600	1550	1800	1702
	3500	1270	2270	4540	5°	7°	1600	1510	1787	1669
	4000	1570	2570	5040	5°	7°	1575	1453	1777	1639
3-stage Dual FFL mast	4000	895	1895	5040	5°	5°	1496	1379	1698	1565
	4500	1045	2045	5540	5°	5°	1429	1321	1624	1501
	5000	1195	2195	6040	5°	5°	1366	1265	1554	1441
	5500	1395	2395	6540	5°	3°	1306	1213	1489	1384
3-stage Single FFL Mast	4000	895	1895	5040	5°	5°	1496	1379	1698	1565
	4500	1045	2045	5540	5°	5°	1429	1321	1624	1501
	5000	1195	2195	6040	5°	5°	1366	1265	1554	1441
	5500	1395	2395	6540	5°	3°	1306	1213	1489	1384

For special request, please contact BYD.

ECB20SD MAST TABLE

Mast spec (mm)	h3	h2 (with backrest)	h1	h4	α	β	Residual Capacity (kg)(without attachment)	
							ECB20SD @500MM/@600MM	
2-stage Standard Mast	3000	130	1990	4040	5°	7°	1600	1600
	3500	130	2290	4540	5°	7°	1600	1600
	4000	130	2540	5040	5°	7°	1600	1600
	4500	130	2840	5540	5°	5°	1503	1503
	5000	130	3090	6040	5°	5°	1354	1354
2-stage FFL mast	3000	1000	2040	4040	5°	7°	1600	1600
	3300	1150	2190	4340	5°	7°	1600	1600
	3500	1250	2290	4540	5°	7°	1600	1600
	4000	1500	2540	5040	5°	7°	1575	1575
3-stage Dual FFL mast	4000	893	1893	5040	5°	5°	1496	1496
	4500	1093	2093	5540	5°	5°	1429	1429
	5000	1293	2293	6040	5°	5°	1366	1366
	5500	1443	2443	6540	5°	3°	1306	1306
3-stage Single FFL Mast	4000	893	1893	5040	5°	5°	1496	1496
	4500	1093	2093	5540	5°	5°	1429	1429
	5000	1293	2293	6040	5°	5°	1366	1366
	5500	1443	2443	6540	5°	3°	1306	1306

For special request, please contact BYD.

LOADING CAPACITY

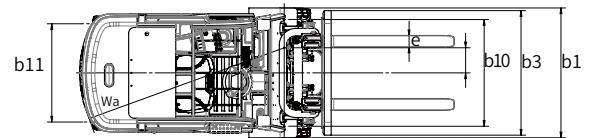
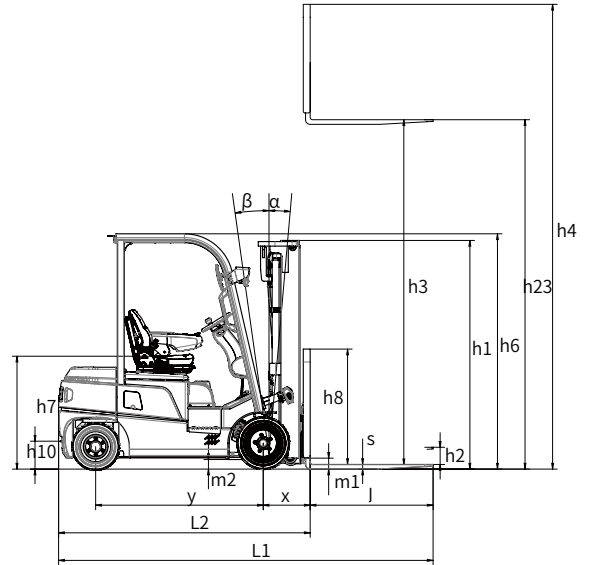
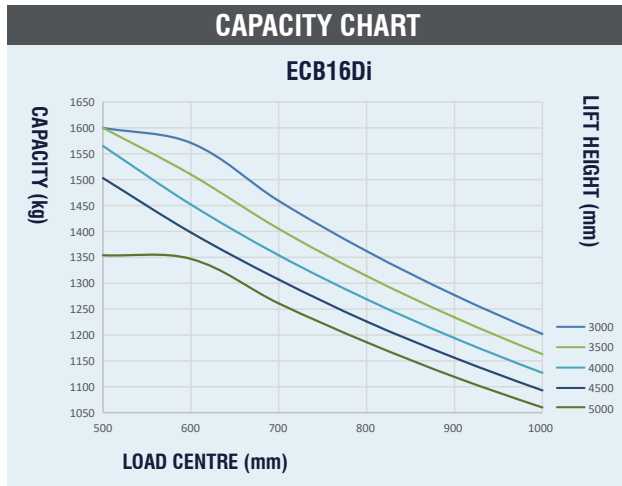

STANDARD FEATURES

- 80V Dual AC drive motor
- 4.8m 3-stage FFL Mast with dual FFL
- Cascade Integral sidershifter
- 4-Way Hydraulic valve
- Full LED lights
- 80V 21.6kwh
- MSG45 seat(basic model)/ MSG65 seat (Comfort model)
- 80V 100A IGBT Charger
- 1070mm forks
- Super Elastic solid tyres
- Electric parking brake
- Battery Auto Switch-off

OPTIONAL FEATURES

- Mast variants
- Attachments upon requests
- MSG 65 Textile/Leather seat
- Full cabin options
- Lights option (Flashing beacon/spot light/rear working light)
- Panoramic Mirror
- Storage box with USB port
- 80V 200A IGBT Charger
- Non-marking tyres
- Battery options:80V 27.2kwh



BYD Europe B.V.

📍 s-Gravelandseweg 256, 3125 BK Schiedam, The Netherlands

☎ 0031 1020 70888

✉ forklift@byd.com

🌐 www.bydforklift.com